

Ministry for Emergencies and Population Protection from the  
Chernobyl NPP Catastrophe Consequences

Academy of Sciences of Belarus

**THE CHERNOBYL CATASTROPHE  
CONSEQUENCES IN THE REPUBLIC OF  
BELARUS**

National Report

Editing:

E. F. Konoplya, Academician  
I. V. Rolevich, Professor

MINSK  
1996

The Chernobyl catastrophe consequences and their overcoming in the Republic of Belarus. National report // Ed. by E.F. Konoplya and I.V. Rolevich - Minsk: Ministry for Emergencies and Population Protection from the Chernobyl NPP catastrophe consequences, 1996, Academy of Sciences of Belarus, 1996, - 88 p.

Research and radiational-ecological monitoring materials implemented by order of the Ministry for Emergencies and Population Protection from the Chernobyl NPP Catastrophe Consequences in Belarus Academy of Sciences, the Ministry of Health, the Academy of Agrarian Sciences of the Ministry of Foodstuff and Agriculture, the Ministry of Forestry and PO "Belarusgeology" and others were used for the report.

Responsible for the issue -

Dr. N. Ya. Borisevich

- © Ministry for Emergencies and Population Protection from the Chernobyl NPP Catastrophe Consequences, 1996
- © Academy of Sciences of Belarus, 1996
- © Designed by Belsens Ltd., 1996
- © Translated into English by «Sebitour» Ltd., 1996

## CHAPTER 1 RADIOECOLOGICAL CONSEQUENCES OF THE CHERNOBYL NPP CATASTROPHE

### 1.1. Formation of radioactive contamination

At 01.24 a.m., Moscow time, on April 26, 1986 at the Unit 4 of the Chernobyl NPP there were two explosions, subsequently, that destroyed and broke off the roof of the reactor's building, opened its active zone and released a large amount of uranium fuel, transuranium elements, concrete, graphite. The fire originated. The radioactive substances reached the height of 1,8 km and began moving with air streams to the north-west and north direction through the west and central regions of Belarus.

Radioactive substances of the total activity of about 10 EBq ( $1 \text{ E} = 10^{18}$ ) including 6,3 EBq of radioactive noble gasses were released into the environment. 50-60 % of Iodine and 30-35 % of Caesium contained in the reactor was released. According to some estimations the amount of the blow-out is considered to be much higher.

The formation of radioactive contamination of Belarus began immediately after the reactor's explosion. On April 27-28, 1986 the territory of Belarus was under the influence of the reduced atmospheric pressure. On April 28, 1986 in all the regions of the republic there were rains of torrential character. Since April 29 the air masses with radioactive blow-outs that had moved to the north direction, began to move from the Baltic to Belarus due to the change of directions of air streams. Such air stream transfer was observed up to May 6. Since May 8 there happened the secondary change in the direction of air masses movement and their trajectory passed from Chernobyl to the north direction again.

Meteorological conditions of the radioactively contaminated air masses movement from April 26 to May 10, 1986 together with rains, especially at the end of April and beginning of May, determined the scale of the radioactive contamination of the territory of Belarus. About 2/3 of the radioactive substances in the result of dry and wet sedimentation fell out on its territory.

Radioactive blow-outs led to considerable contamination of the area, settlements, water basins. The Caesium-137 contamination of the territory of Belarus over  $37 \text{ kBq/m}^2$  made up 23 % of the total territory of the republic. For comparison, for Ukraine it makes up 5 %, Russia - 0,6 % (Fig.1.1.). This testifies to more complicated and heavier consequences of the Chernobyl catastrophe for Belarus in comparison with Russia and Ukraine.

The increase of radioactivity in the result of the Chernobyl NPP catastrophe has been registered at the distance of thousands of kilometers. At the initial stage the main contribution to the environment contamination and formation of exposure doses of population made caesium-137 (half-life period - 30 years), strontium-90 (29 years), plutonium-238 (88 years), plutonium-239 ( $2,4 \times 10^4$  years), plutonium-240 (6537 years), plutonium-241 (14,4 years), caesium-134 (2 years), cerium-144 (284 days), ruthenium-106 (368 days), iodine-131, -132, -133, -135 (up to 8 days), lanthanum-140 (40 hours), neptunium-239 (2 days), barium-140 (13 days), molybdenum -99 (66 hours), strontium-89 (50 days) and about 20 radionuclides more with short half-life periods.

Taking into account the scale and severity of the Chernobyl NPP catastrophe consequences in July 1990 the Supreme Soviet of Belarus announced the territory of the republic a zone of ecological calamity. The State programme on the overcoming of the Chernobyl NPP

catastrophe consequences for 1990-1995 was adopted, aimed at providing safe living conditions for the population in the regions affected by radioactive contamination.

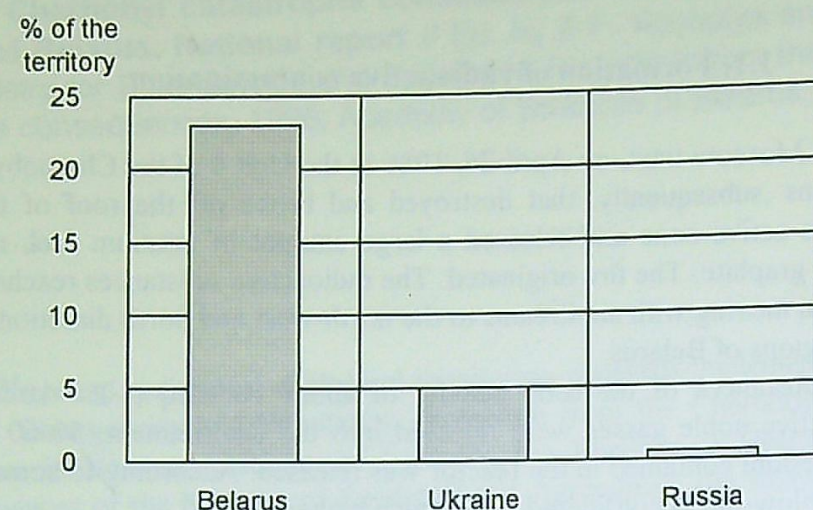

Fig.1.1. Contamination of the territories of Belarus, Ukraine and Russia with Cs-137 density over 37 kBq/m<sup>2</sup> (in % of the total area)

The important task in the post-accident period has been the estimation of the radioactive contamination of the territory of Belarus and creation of specially oriented monitoring. In 1986 there was carried out the radiation examination of the territory of the republic, in the first place, of settlements, agricultural lands and forests. The first cartograms of the radiation situation were prepared already in June 1986.

In the subsequent period the cartograms of Cs-137, Sr-90 and isotopes of plutonium content in soil were published every three years. Taking into account the nonuniformity of the radioactive contamination and the necessity of realization of protective measures for the reduction of exposure doses and providing the safety of population's living conditions on the contaminated areas, the investigation of individual farms was done. Every owner was given a radiation certificate.

In accordance with the article 40 of the Law of the Republic of Belarus "On legal treatment of territories affected by radioactive contamination as a result of the Chernobyl NPP catastrophe" the total estimation of the radiation situation on the territory of the republic (radiation monitoring) and methodical management is carried out by the Committee on Hydrometeorology of the Ministry for Emergencies and Population Protection from the Chernobyl NPP catastrophe consequences. (Fig.1.2.)

Taking into account the radioactive contamination of soil, air, water systems, flora, fauna and other ecosystems by different radionuclides and the necessity of the complex approach to the estimation of the radiation situation, the efforts of the Committee on Hydrometeorology of the Ministry for Emergencies, the Academy of Sciences, the Ministries of Health, Agriculture and Foodstuff, Forestry and Housing and other institutions have been consolidated. For the study of the radionuclides behaviour in different ecosystems and elaboration of forecasting, fundamental scientific researches have been organized.

With regard to the specific of radioactive contamination of some regions, their landscape-geochemical peculiarities and other factors there has been organized the network of the constant environment monitoring on 181 reference sites (Fig.1.3.). There are 31 constant points of

air monitoring, 24 sections of the estimation of the river surface waters and 85 wells for underground waters investigation.

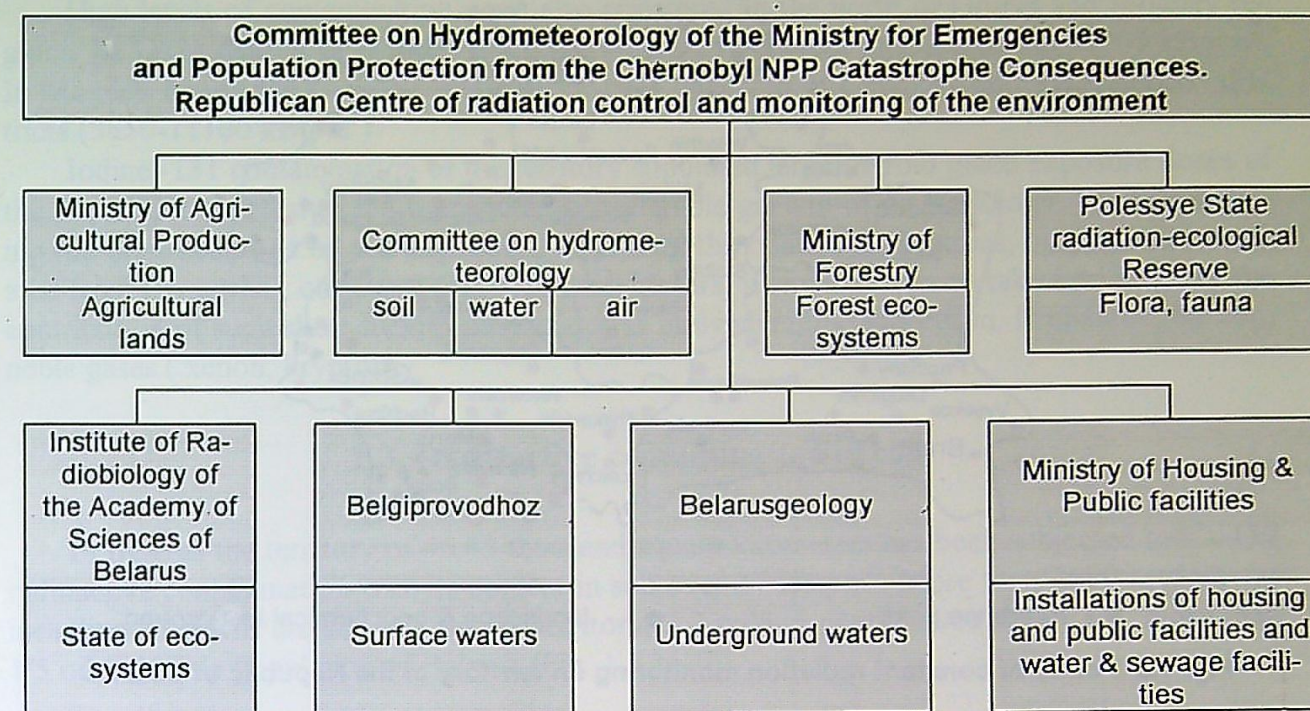

Fig.1.2. The system of monitoring of the radioactive contamination of the environment of the Republic of Belarus

On 54 hydrometeorological stations the measurements of the exposional dose power of gamma-radiation are measured daily.

## 1.2. Radioactive iodine contamination of the territory of the Republic of Belarus

In the initial post-accident period the considerable increase of the exposional dose power of gamma-radiation was registered practically on the whole territory of the Republic of Belarus. The levels of radioactive contamination by short-lived iodine radionuclides in many regions of the republic were so high that the irradiation of millions of people caused by them has been qualified by experts as the period of "iodine blow".

Since the direct measurements of iodine were not carried out in the first days after the catastrophe, the scientists and experts of the republic have made a reconstruction of iodine-131 distribution on the territory of Belarus on May 10, 1986 (Fig.1.4.).

In April-May 1986 the highest levels of iodine-131 contamination were registered in the neighbouring (10-30km) zone in Bragin, Khojniki, Narovlya districts of Gomel region where its content in soils made up 37000 kBq/m<sup>2</sup> and more. In Chechersk, Korma, Buda-Koshelevo, Dobrush districts levels of contamination reached 18500 kBq/m<sup>2</sup>.



● - reference point      ◆ - landscape & geochemical test-ground

Fig. 1.3. Points of constant radiation monitoring on territory of the Republic of Belarus

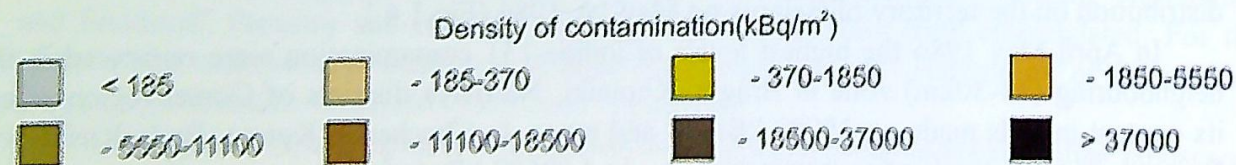
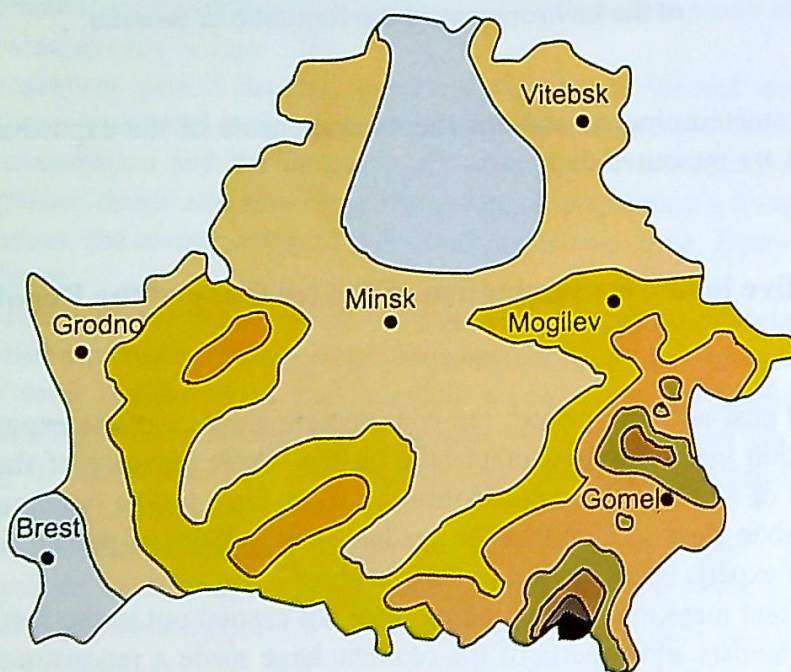

Fig. 1.4. Distribution of iodine-131 in soil on the territory of the Republic of Belarus on May 10, 1986 (reconstruction)

The following south-west districts were also subjected to considerable contamination: Elsk, Lechitsy, Zhitkovichi, Petrikov districts of Gomel region and Pinsk, Luninets, Stolin districts of Brest region.

High levels of contamination were also registered in the north of Gomel and Mogilev regions. In Vetka district of Gomel region the iodine-131 content in soil reached 20000 kBq/m<sup>2</sup>. In Mogilev region the largest contamination was observed in Cherikov and Krasnopolski districts (5550-11100 kBq/m<sup>2</sup>).

Iodine -131 contamination of the territory stipulated large thyroid gland exposure doses of the population that led to the subsequent considerable growth of its pathology. While estimating the dose absorbed by the population inhabiting the contaminated areas, by persons evacuated from the settling out zone, and by the liquidators, it is necessary to take into account the contribution of such short-lived radionuclides as molybdenum, technetium, lanthanum, barium, noble gases ( xenon, krypton).

### 1.3. Radioactive contamination of soil

In Belarus the territory of 46,45 thousand square kilometers has been subjected to Cs-137 radioactive contamination with its content in soil over 37 kBq/m<sup>2</sup>. More than 3600 settlements including 27 towns are situated on the territory, 2,2 million people lived there ,e.i., more than 1/5 of the whole population of Belarus (Fig. 1.5.).

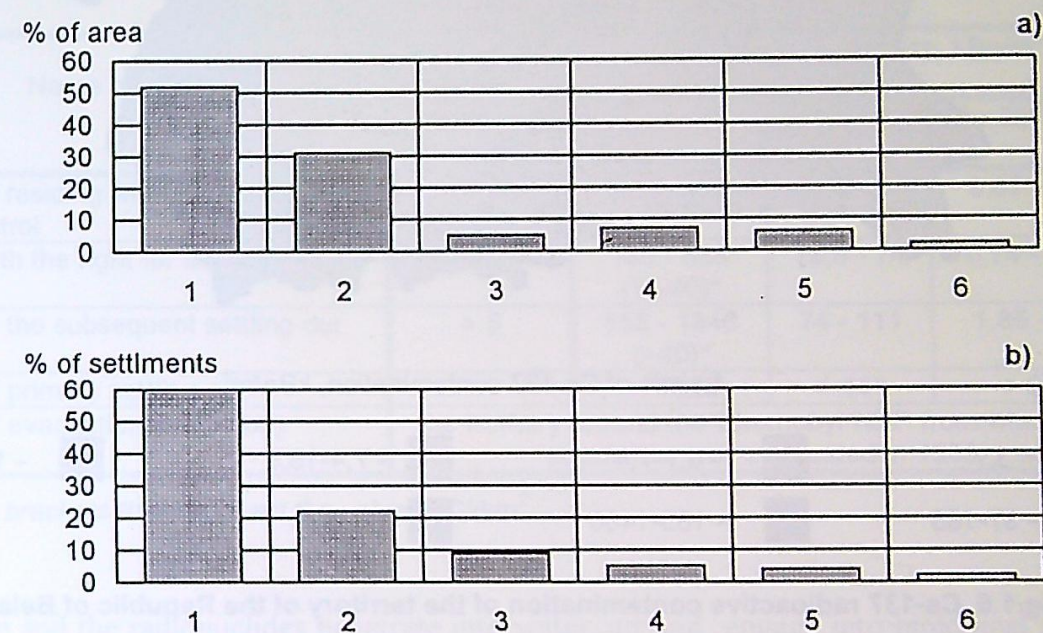

Fig.1.5. The area (a) and the number of settlements (b) subjected to Cs-137 radioactive contamination over 37 kBq/m<sup>2</sup> in the regions of Belarus (1-Gomel, 2-Mogilev, 3-Brest, 4-Minsk, 5-Grodno, 6- Vitebsk)

In the result of the Chernobyl NPP catastrophe the most contaminated are Gomel, Mogilev and Brest regions.

Radioactive contamination is of nonuniform, "spotty" character even within the limits of one settlement. So, in Kolyban of Bragin district, Gomel region, the level of Cs-137 contamination varies from 170 to 2400 kBq/m<sup>2</sup>. The maximum local level of the Cs-137 content in soil in the neighbouring Chernobyl NPP zone has been registered in the village of Kruki of Bragin district, Gomel region - 59200 kBq/m<sup>2</sup>, and in the distant zone at the distance of 250 km - in Chudyany of Cherikov district Mogilev region - 51000 kBq/m<sup>2</sup> (Fig.1.6.).

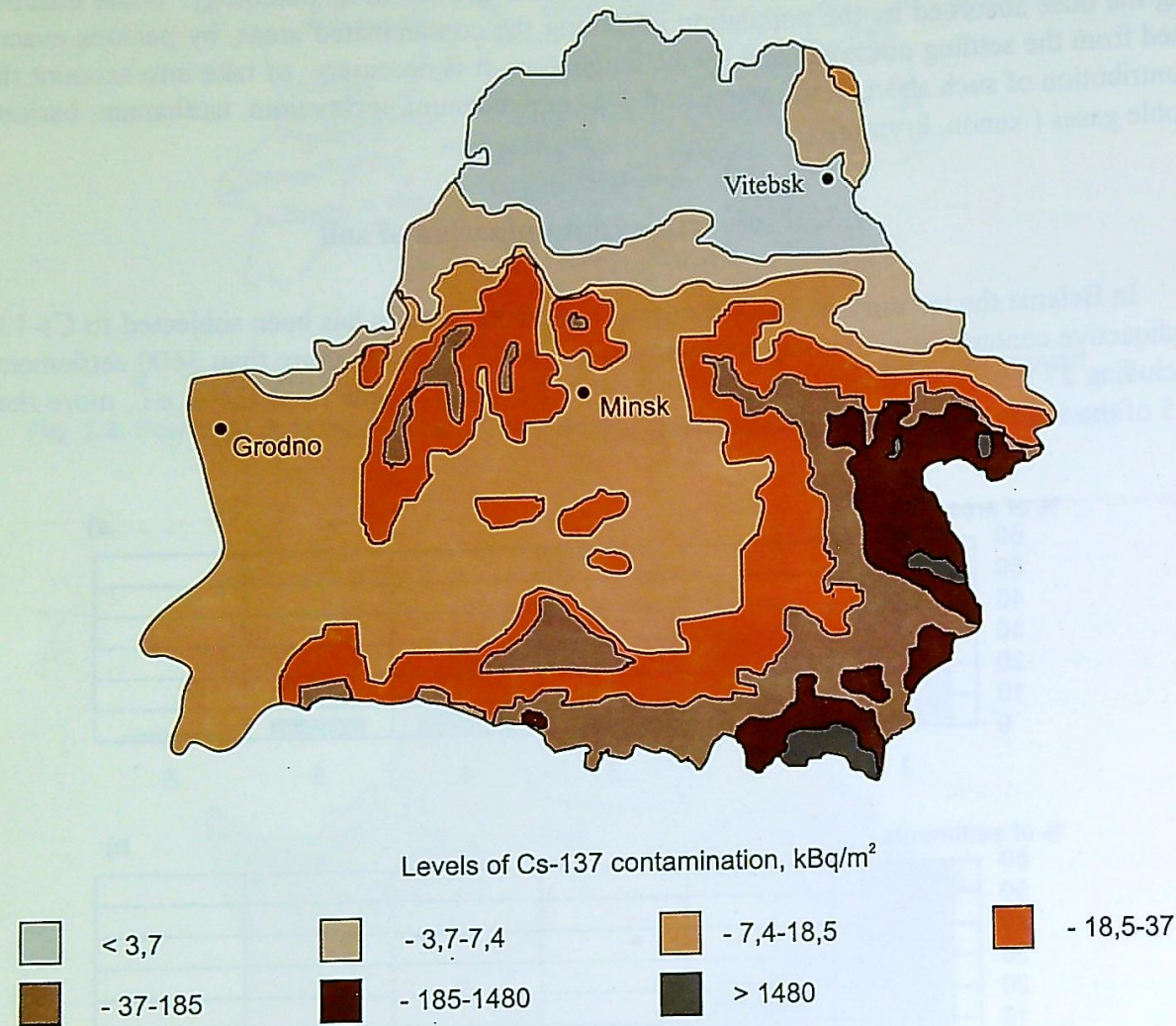

Fig.1.6. Cs-137 radioactive contamination of the territory of the Republic of Belarus

In Brest region the radioactive contamination affected the south-east part, where in 6 districts Cs-137 content in soil, mainly, is within the limits of 37 to 185 kBq/m<sup>2</sup>, and maximum levels reach 400 kBq/m<sup>2</sup>. In Minsk, Grodno regions and in 4 settlements of Vitebsk region Cs-137 content exceeds 37 kBq/m<sup>2</sup>.

On the rest of the territory of Belarus the Cs-137 levels of contamination of soil are also higher than the pre-accident indices and only in north-west districts of Vitebsk region are comparable with global fall-outs.

The contamination of the territory of the republic by Sr-90 (Fig.1.7.) is of more local character. The levels of its content in soil over 5,5 kBq/m<sup>2</sup> have been discovered on the area of 21,1 thousand square km that makes up 10 % of the territory of the republic.

The maximum levels of Sr-90 have been registered within the limits of 30km from Chernobyl NPP and reach the level of 1800 kBq/m<sup>2</sup> in Khojniki district of Gomel region. The highest content of it in soils of the distant zone have been discovered at the distance of 250 km - in Cherikov district of Mogilev region and makes up 29 kBq/m<sup>2</sup> and also in the north part of Gomel region in Vetka district - 137 kBq/m<sup>2</sup>.

The contamination of soils by isotopes of plutonium-238,-239,-240 over 0,37 kBq/m<sup>2</sup> (Fig. 1.8.) covers about 4,0 thousand km<sup>2</sup> or about 2 % of the territory of the republic. These territories are mainly situated in Gomel region (Bragin, Narovlya, Rechitsa, Dobrush and Loev districts) and Cherikov district of Mogilev region. So, the contamination of soil by isotopes of plutonium from 0,37 to 3,7 kBq/m<sup>2</sup> has been registered in Gomel region. The content of plutonium in soil reaching 3,7 kBq/m<sup>2</sup> is characteristic of the 30-km zone of the Chernobyl NPP. The highest levels are observed in Khojniki district - more than 111 kBq/m<sup>2</sup>.

According to article 4 of the Law "On legal treatment of the territories affected by radioactive contamination as a result of the Chernobyl NPP catastrophe" the territory of the republic is divided into zones depending on the radionuclides radioactive contamination of soils and the average effective dose (Table 1.1.).

Table 1.1. Zoning of the territory of the Republic of Belarus according to the level of radioactive contamination and the degree of dose load on the population

Name of the zone	Equivalent dose, mSv per year	Contamination density, kBq/m <sup>2</sup>		
		Cs-137	Sr-90	Pu-238,-240
Zone of residing with periodical radiation control	< 1	37 - 185 (1-5)*	5,55 - 18,5	0,37 - 0,74
Zone with the right for settling out	< 5 > 1	185 - 555 (15-40)*	18,5 - 74	0,74 - 1,85
Zone of the subsequent settling out	> 5	555 - 1840 (>40)*	74 - 111	1,85 - 3,7
Zone of primary settling out		> 1840	> 111	> 3,7
Zone of evacuation(alienation)	the territory around the Chernobyl NPP from which the population was evacuated in 1986			

\* - in brackets there is given the value in Ci/km<sup>2</sup>

From soil the radionuclides penetrate into water, air and engage into biological cycles of migration creating, thereby, multitude of ways of external and internal irradiation of the population.

The scale of these processes is influenced by a number of factors, first of all, by the speed of vertical migration. Among them we should point out - the type of soil and its mineral and organic composition, landscape-geochemical peculiarities of the region, physico-chemical state of the radionuclides and others.

In Fig.1.9. there is shown the typical character of Cs-137, Sr-90, Pu-239,-240 and americium-241 distribution on vertical profile of the soddy-podzolic soil at various distances from the Chernobyl NPP.

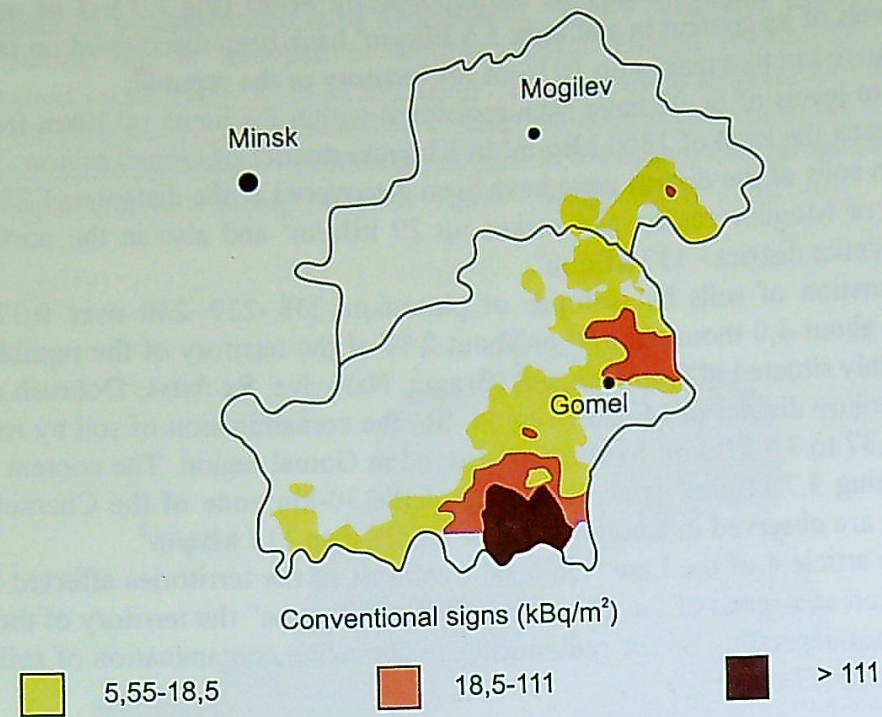

Fig. 1.7. Sr-90 content in soil on the territory of Gomel and Mogilev regions on 01.01.1995

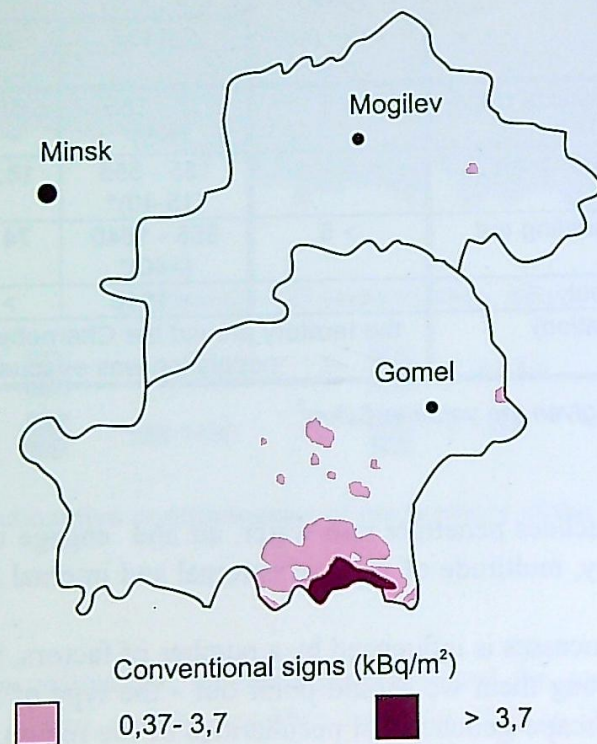
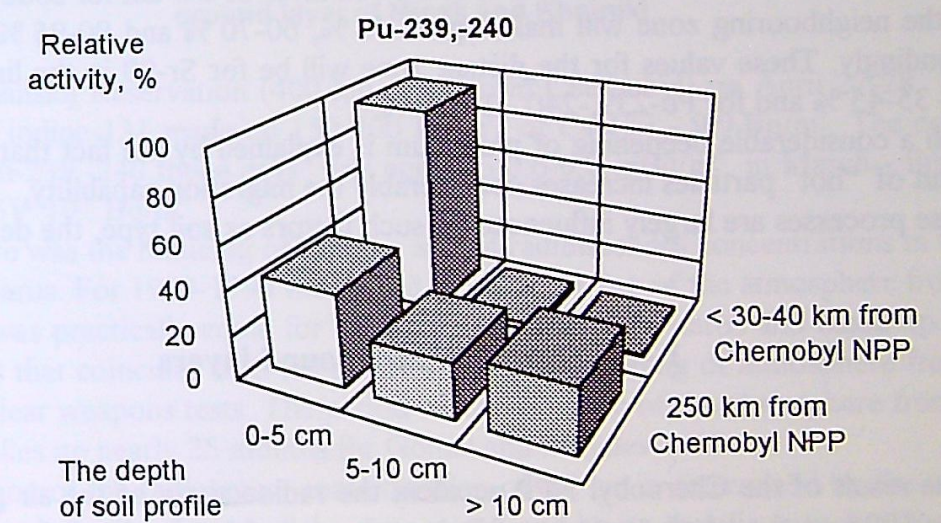
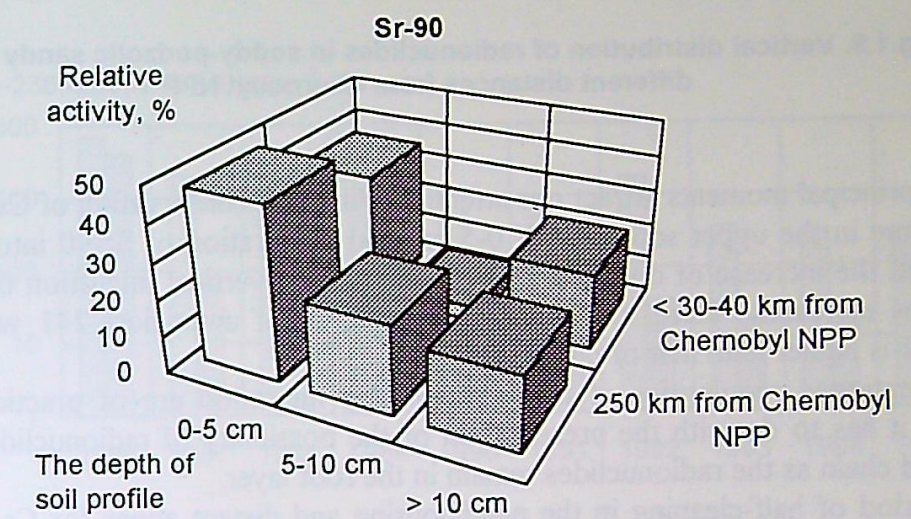
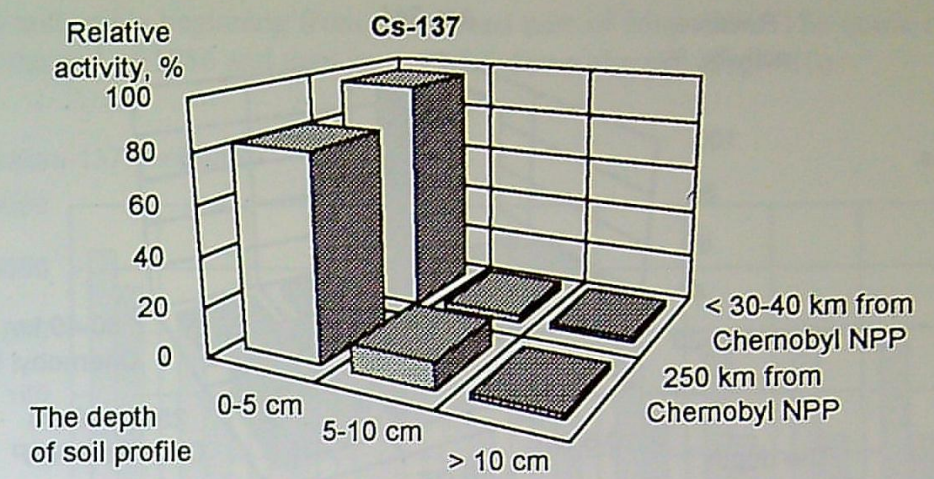

Fig. 1.8. Plutonium-238,-239,-240 content in soil on the territory of Gomel and Mogilev regions on 01.01.1995



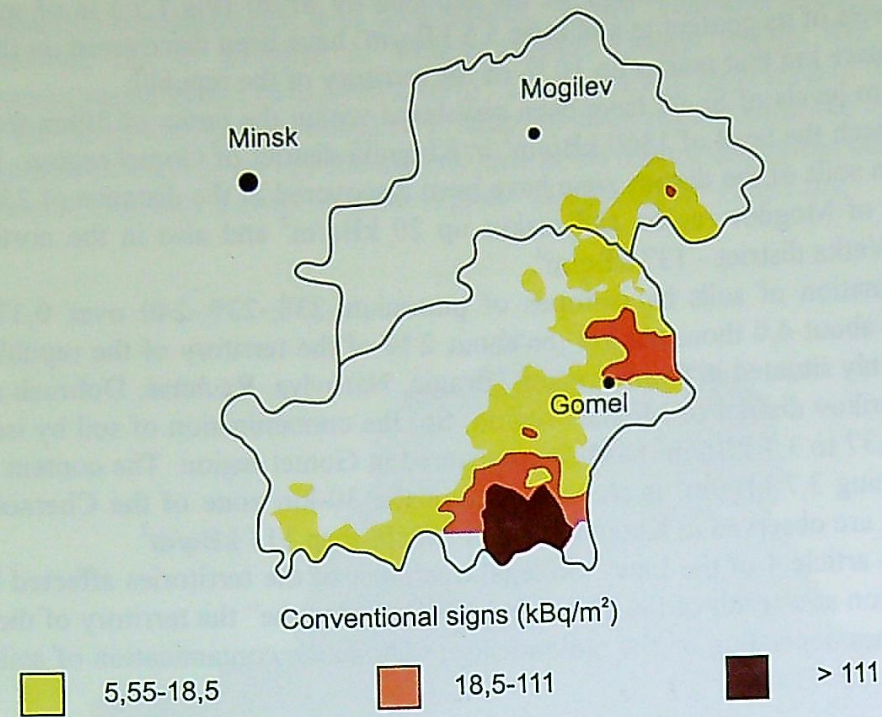

Fig. 1.7. Sr-90 content in soil on the territory of Gomel and Mogilev regions on 01.01.1995

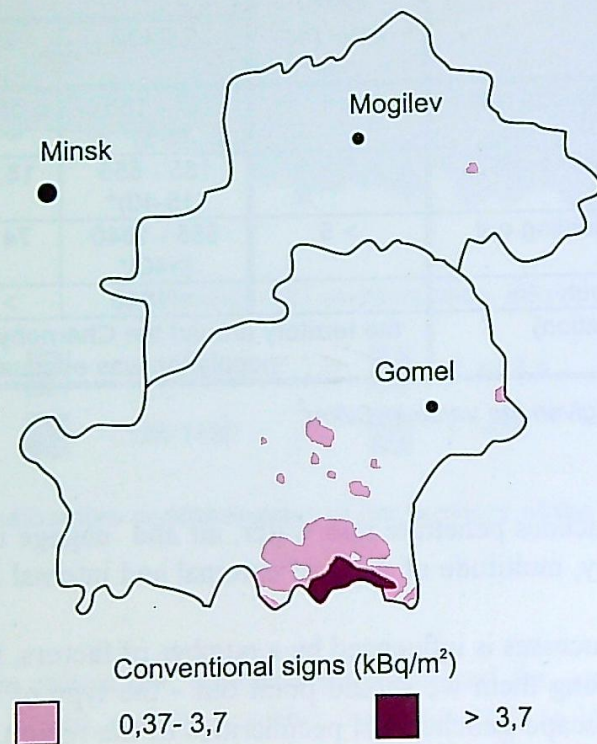
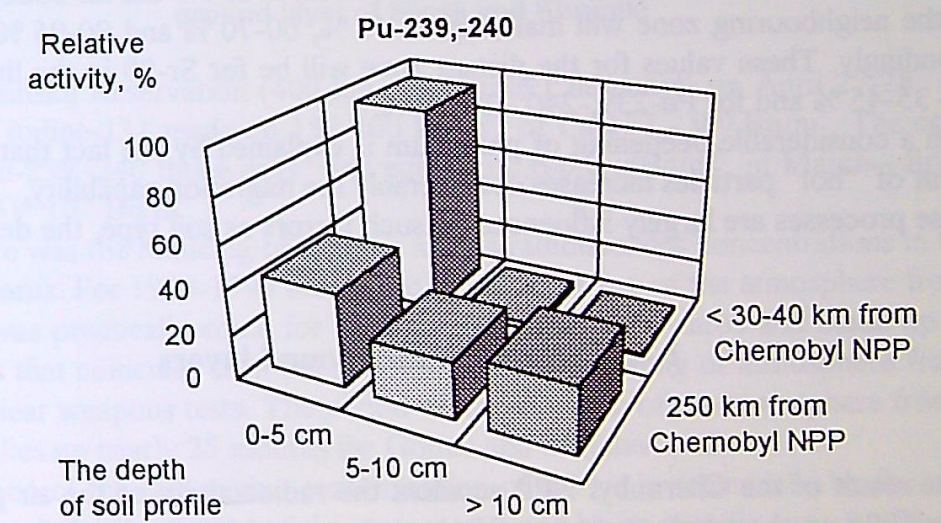
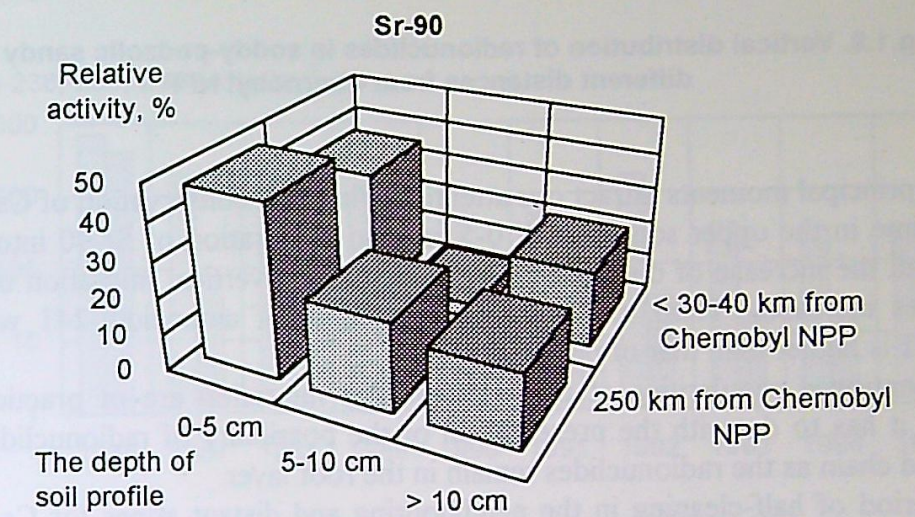
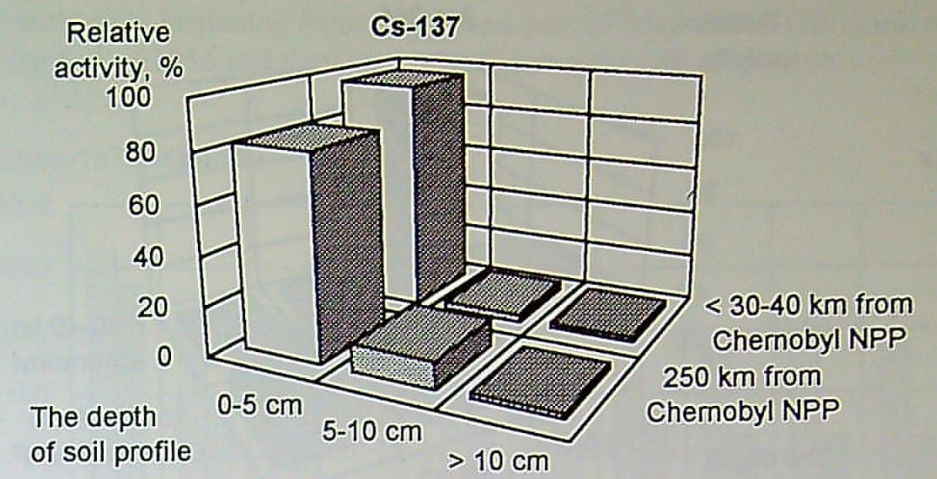

Fig. 1.8. Plutonium-238,-239,-240 content in soil on the territory of Gomel and Mogilev regions on 01.01.1995



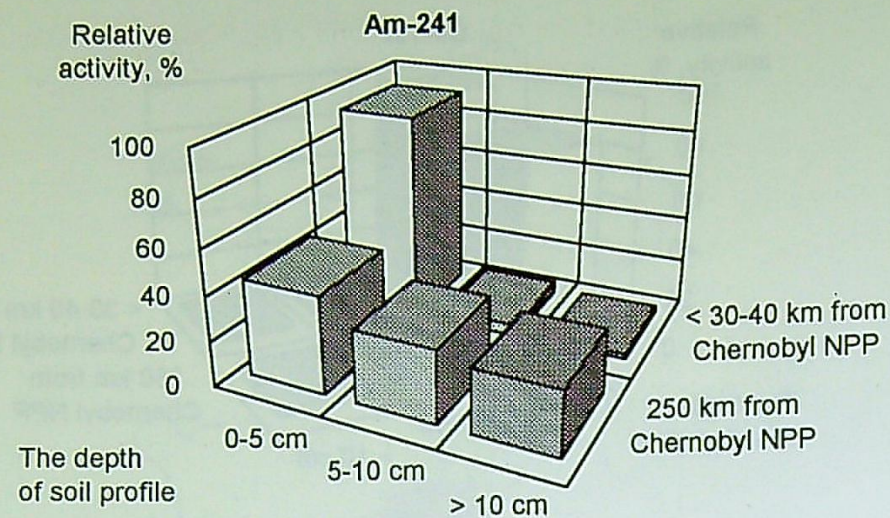

Fig.1.9. Vertical distribution of radionuclides in soddy-podzolic sandy soil at different distances from Chernobyl NPP

Three principal moments attract our attention. First, the conservation of Cs-137 for a long period of time in the upper soil layer of 0-5 cm and penetration of Sr-90 into deeper layers. Second, with the increase of distance from the station the vertical migration of practically all radionuclides increases. Third, the migration capability of americium-241 which originates from Pu-241 is higher than that of plutonium.

The mentioned regularities of the radionuclides migration are of practical importance. First of all, it has to do with the preservation of the possibility of radionuclides introduction into the food chain as the radionuclides remain in the root layer.

The period of half-cleaning in the neighbouring and distant zones for Cs-137 makes up 24-27 and 10-17 years correspondingly. For Sr-90 the half-cleaning period of the soil layer of 0-5 cm for the neighbouring and distant zones is less and makes up 7-12 years. To 2006 the content of Sr-90, Cs-137 and Pu-239,-240 in the soil layer of 0-5 cm for soddy-podzolic sandy soils of the neighbouring zone will make up 30-40 %, 60-70 % and 90-95 % of their reserve correspondingly. These values for the distant zone will be for Sr-90 in the limits of 15-25 %, Cs-137 - 35-45 % and for Pu-239,-240 - 10-20 %.

Such a considerable deepening of plutonium is explained by the fact that this element releasing out of "hot" particles increases considerably the migration capability.

These processes are largely influenced by such factors as soil type, the degree of moistening, etc.

#### 1.4. The state of air ground layers

In the result of the Chernobyl NPP accident the radioactivity of the air ground layers in April-May 1986 on the whole territory of Belarus increased hundreds of thousand times. The maximum radionuclides concentration in the air was observed on April 27-28. The air activity

began to reduce noticeably beginning from the second part of May 1986. The quick reduction continued up to the end of 1986 and then its rates fell down sharply. (Fig.1.10).

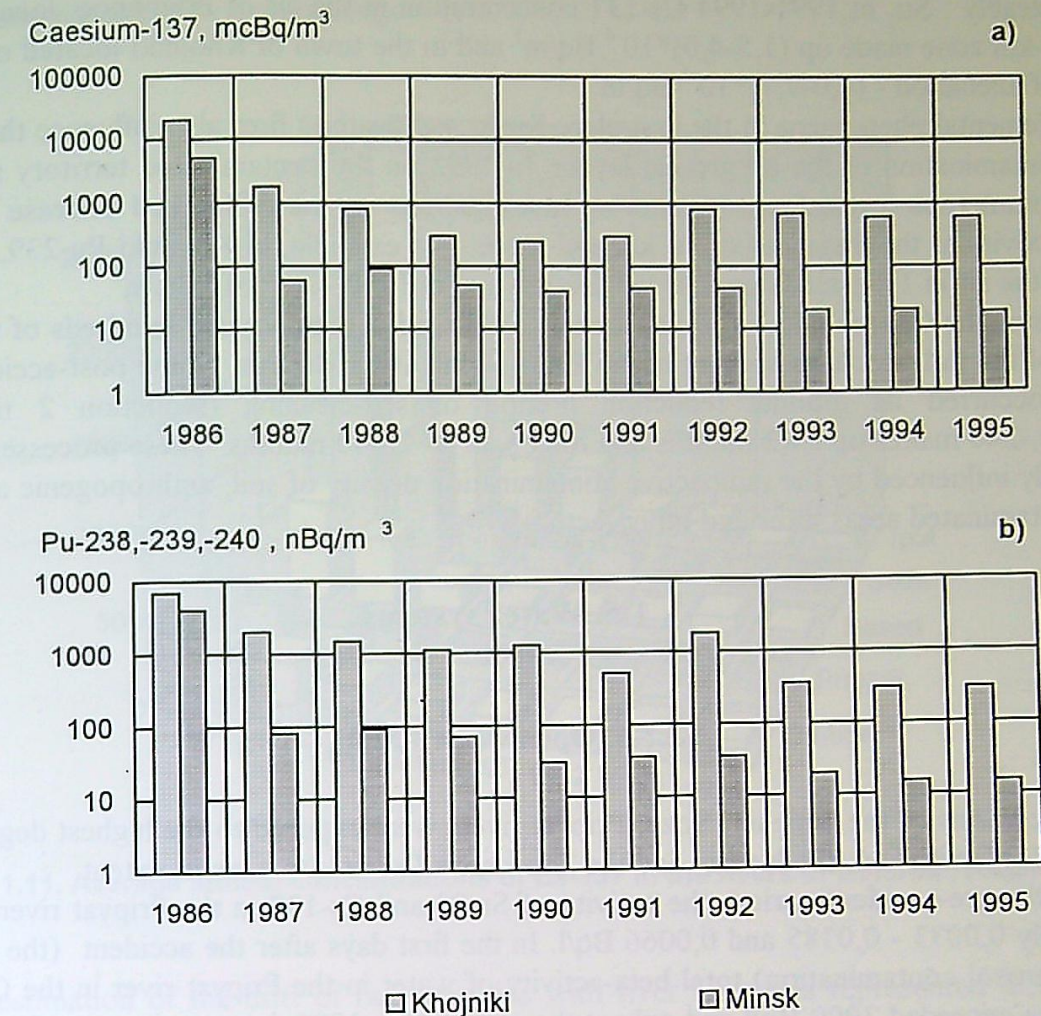

Fig.1.10. Average annual concentration of Cs-137 (a) and isotopes of plutonium (b) in the air ground layer of Minsk and Khojniki

In the Berezinskij Reservation (400 km north from Chernobyl) on April 27-28, 1986 the concentration of iodine-131 made up 150-200 Bq/m<sup>3</sup>, of Cs-137 - 9,9 Bq/m<sup>3</sup>. The concentration of plutonium-239,-240 those days was equal to 0,6-0,8 mBq/m<sup>3</sup>, in March - first half of April 1986 - (3-5) \* 10<sup>-9</sup> Bq/m<sup>3</sup>.

Further there was the reducing of average annual radionuclides concentrations in the air of the towns of Belarus. For 1990-1994 the period of half-cleaning of the atmosphere from plutonium-239,-240 was practically equal for all regional centres of Belarus and made up on average 14,2 months that coincides with the period of the half-cleaning of atmosphere from plutonium during nuclear weapons tests. The period of half-cleaning of the atmosphere from Cs-137 is higher and makes up nearly 25 months for Gomel and Mogilev.

The formation of the radioactive contamination of the air is determined by the content of dust in the surface boundary layers of the atmosphere and by its specific activity. Dust content in the zone of settling out due to the removing of technogenous load and formation of the plant cover is the lowest and in the spring period makes up about 25 mcg/m<sup>3</sup>. In the inhabited re-



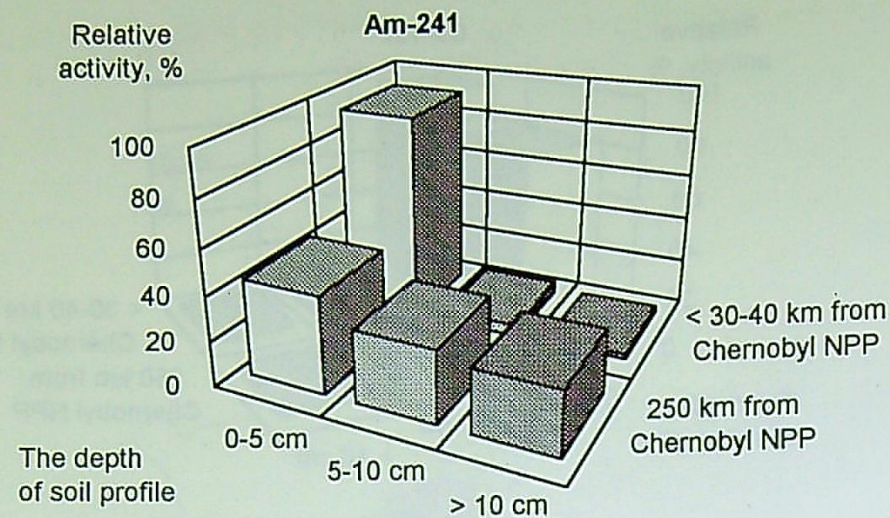

Fig.1.9. Vertical distribution of radionuclides in soddy-podzolic sandy soil at different distances from Chernobyl NPP

Three principal moments attract our attention. First, the conservation of Cs-137 for a long period of time in the upper soil layer of 0-5 cm and penetration of Sr-90 into deeper layers. Second, with the increase of distance from the station the vertical migration of practically all radionuclides increases. Third, the migration capability of americium-241 which originates from Pu-241 is higher than that of plutonium.

The mentioned regularities of the radionuclides migration are of practical importance. First of all, it has to do with the preservation of the possibility of radionuclides introduction into the food chain as the radionuclides remain in the root layer.

The period of half-cleaning in the neighbouring and distant zones for Cs-137 makes up 24-27 and 10-17 years correspondingly. For Sr-90 the half-cleaning period of the soil layer of 0-5 cm for the neighbouring and distant zones is less and makes up 7-12 years. To 2006 the content of Sr-90, Cs-137 and Pu-239,-240 in the soil layer of 0-5 cm for soddy-podzolic sandy soils of the neighbouring zone will make up 30-40 %, 60-70 % and 90-95 % of their reserve correspondingly. These values for the distant zone will be for Sr-90 in the limits of 15-25 %, Cs-137 - 35-45 % and for Pu-239,-240 - 10-20 %.

Such a considerable deepening of plutonium is explained by the fact that this element releasing out of "hot" particles increases considerably the migration capability.

These processes are largely influenced by such factors as soil type, the degree of moistening, etc.

#### 1.4. The state of air ground layers

In the result of the Chernobyl NPP accident the radioactivity of the air ground layers in April-May 1986 on the whole territory of Belarus increased hundreds of thousand times. The maximum radionuclides concentration in the air was observed on April 27-28. The air activity

began to reduce noticeably beginning from the second part of May 1986. The quick reduction continued up to the end of 1986 and then its rates fell down sharply. (Fig. 1. 10).

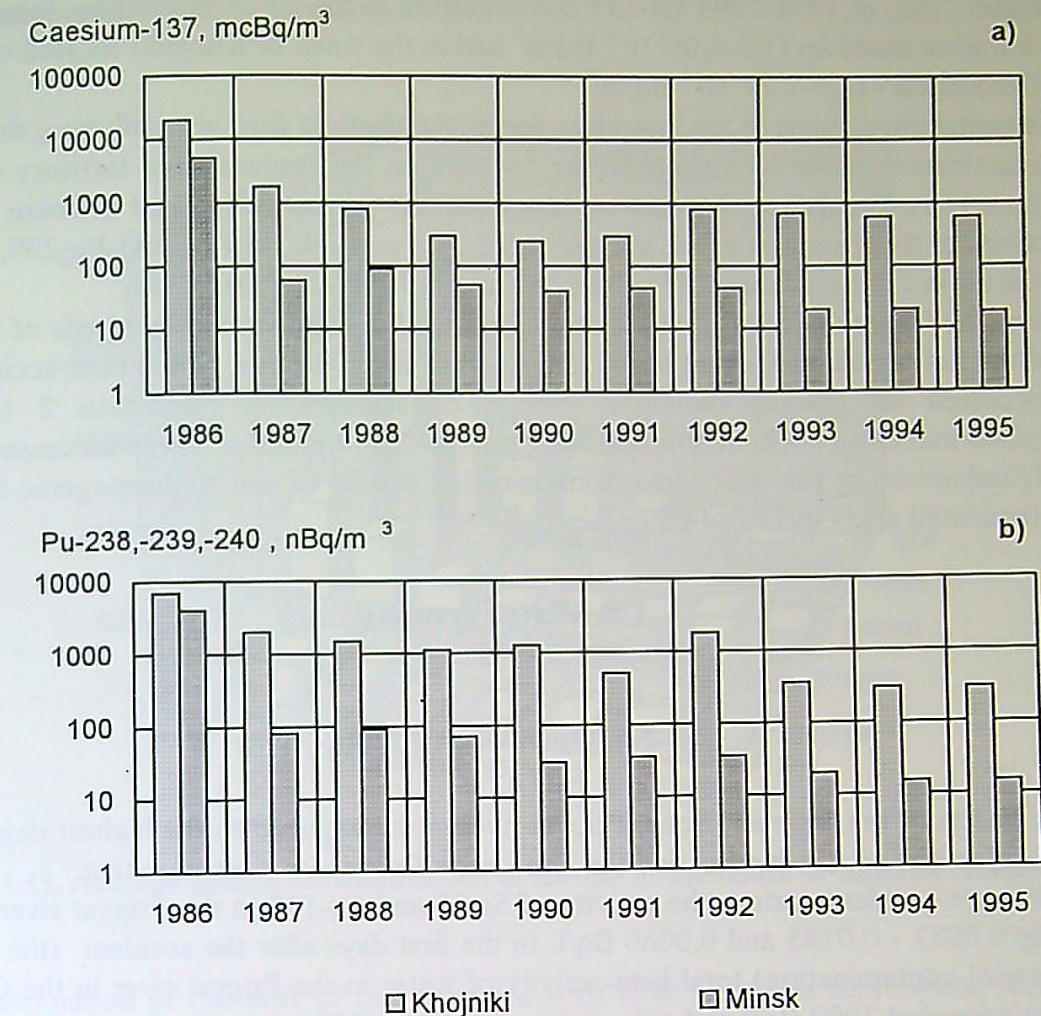

Fig.1.10. Average annual concentration of Cs-137 (a) and isotopes of plutonium (b) in the air ground layer of Minsk and Khojniki

In the Berezinskij Reservation (400 km north from Chernobyl) on April 27-28, 1986 the concentration of iodine-131 made up 150-200 Bq/m<sup>3</sup>, of Cs-137 - 9,9 Bq/m<sup>3</sup>. The concentration of plutonium-239,-240 those days was equal to 0,6-0,8 mBq/m<sup>3</sup>, in March - first half of April 1986 - (3-5) \* 10<sup>-9</sup> Bq/m<sup>3</sup>.

Further there was the reducing of average annual radionuclides concentrations in the air of the towns of Belarus. For 1990-1994 the period of half-cleaning of the atmosphere from plutonium-239,-240 was practically equal for all regional centres of Belarus and made up on average 14,2 months that coincides with the period of the half-cleaning of atmosphere from plutonium during nuclear weapons tests. The period of half-cleaning of the atmosphere from Cs-137 is higher and makes up nearly 25 months for Gomel and Mogilev.

The formation of the radioactive contamination of the air is determined by the content of dust in the surface boundary layers of the atmosphere and by its specific activity. Dust content in the zone of settling out due to the removing of technogenous load and formation of the plant cover is the lowest and in the spring period makes up about 25 mcg/m<sup>3</sup>. In the inhabited re-

gions, especially in the course of agricultural and other works, dust formation increases considerably. In this period in spite of the lower radionuclides contamination degree on the territories neighbouring the settling out zone specific radioactivity of the air ground layer increases considerably. So, in 1991-1994 Cs-137 concentration in the air of Pogonnoe, located within the 30-km zone made up  $(1,5-4,0) \cdot 10^{-4}$  Bq/m<sup>3</sup> and in the town of Khojniki located outside the zone of alienation -  $(4,0-7,7) \cdot 10^{-4}$  Bq/m<sup>3</sup>.

Elemental phenomena in the first place forest and peatbog fires also influence the radioactive contamination of the air ground layers. In 1992 on the contaminated territory there happened numerous forest fires. Monitoring investigations registered marked increase of the air radioactivity at the distances of 40 km and more. For example, in Khojniki Pu-239,-240 content in the air in 1991 made up  $7,4 \cdot 10^{-7}$  Bq/m<sup>3</sup>, and in 1992 -  $2,3 \cdot 10^{-6}$  Bq/m<sup>3</sup>.

Thus, the Chernobyl NPP catastrophe in 1986 led to the increase hundreds of thousands times of the radionuclides content in the atmospheric air of Belarus. In the post-accident years there occurred its gradual reduction. Period of self-cleaning (reduction 2 times) for Pu-239,-240 makes up 14,2 months and for Cs-137 - 25-40 months. These processes are considerably influenced by the radioactive contamination density of soil, anthropogenic activity on the contaminated areas, fires and other factors.

## 1.5. Water systems

### 1.5.1. Open water basins

The basins of the Dnieper, Sozh, Pripyat rivers were exposed to the highest degree of radiation contamination, the Neman and the Zapadnaya Dvina - to a lesser extent.

In the pre-accident period, the activity of Sr-90 and Cs-137 in the Pripyat river were respectively 0,0033 - 0,0185 and 0,0066 Bq/l. In the first days after the accident (the period of initial aerosol contamination) total beta-activity of water in the Pripyat river in the Chernobyl NPP area exceeded 3000 Bq/l and only at the end of May 1986 decreased up to 150-200 Bq/l. Maximum concentration of Pu-239 in the Pripyat water made 0,37 Bq/l.

The highest activity of Sr-90 (1,59 up to 2,70 Bq/l) is now registered in the water of the rivers Braginka, Zhelon, Rotovka and Nesvich, in the drainage territories with a high density of radioactive contamination and the Pripyat former river-beds on the resettlement zone territory. For the period 1987-1994 average annual concentrations of Cs-137 decreased as well (Fig. 1.11). Similar maximum activities are characteristic to Cs-137 (0,6-2,45 Bq/l).

In the migration of Cs-137 into the river flow, its drift on solid suspensions (from 10 to 35-40% of the general isotope activity) is of major importance. During floods the general activity increases. For example, in the Braginka river, near the settlement of Bragin, it increased in 1993 from 0,26 Bq/l to 0,33 Bq/l on Cs-137 and from 0,09 Bq/l to 0,17 Bq/l on Sr-90. The share of activity connected with solid suspensions increases synchronically as well.

Unlike Cs-137, the greater part of Sr-90 (50-99 %) migrates in a dissolved state. The ability of river waters to self-cleaning is explained by constant change of water masses, falling out of radionuclides in river bed sediments to beds, and partly by sorption processes of radionuclides in a dissolved state with river bed sediments and minerals and organic substances. During the flood seasons the conversion of highly active river-bed sediments into a suspended state is observed that leads to multiple increase of river waters radioactivity. According to ra-

dioactive contamination the components of the water ecosystems are placed in the following order: river-bed sediments > hydrobionts > water. If water and, in a smaller degree, sediments are characterized by decrease of Cs-137 and Sr-90 content, their concentration in the river-bed sediments and water plants is increasing.

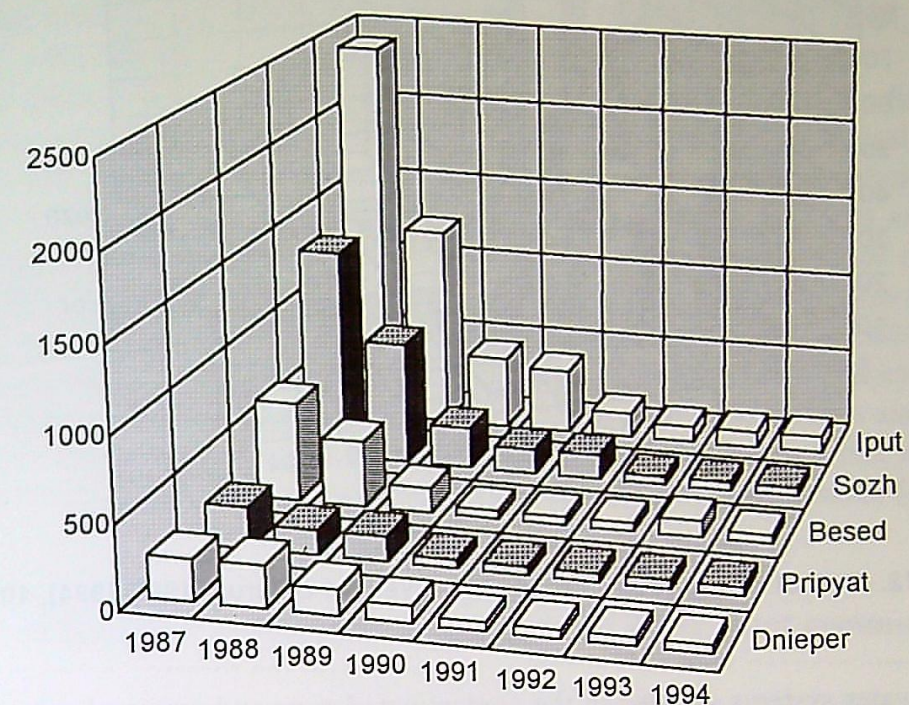

Fig. 1.11. Average annual concentrations of Cs-137 in the rivers of Belarus, (Bq/m<sup>3</sup>)

The estimation of the drift of radionuclides with river waters is represented in the Fig. 1.12. In particular, the main drift of Cs-137 to the Dnieper comes from the Belarussian-Bryansk caesium spot with the Sozh river flow, moreover, for the period 1987-1994 the drift decreased 20 times. The similar changes are noticed in respect of other rivers as well, that indicates the insignificant contribution of this process to the drift of radionuclides.

The process of radionuclides contamination of land-locked basins took place, as well as for rivers, at the expense of aerosol fall out to the water surface and washing off from the water-collecting areas. Because of the limited water exchange the lake-type systems came up practically to the balanced state with marked seasonal fluctuations of radionuclides concentrations in water and biota.

In lakes radionuclides are mainly concentrated in river-bed sediments and biota. Accumulation of radionuclides in hydrobionts with its annual atrophy and flow absence leads to increasing of their accumulation in river-bed sediments. This causes the preservation of sufficiently high level of radionuclides content in the land-locked water systems components. For example, the concentration of Cs-137 in the water of the lake Svyatskoye (Vetka district, Gomel region) makes up 8,7 Bq/l and 3,7 kBq/kg in biota, and in one of the final sections of the lake trophic chains - fish - depending on the type 18,0-39,0 kBq/kg (of dry mass) that can increase considerably the dose when it is used as food.

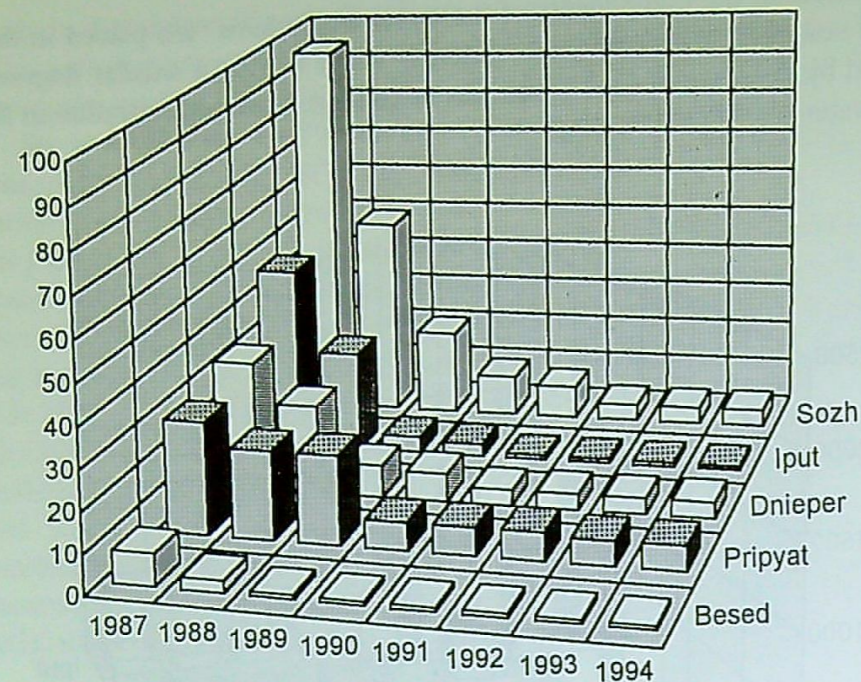

Fig. 1.12. Annual distribution of Cs-137 by rivers of Belarus (1987-1994),  $10^{11}$  Bq

For lake water systems situated in the contaminated zone and removed out of the anthropogenic process the tendency to their growth over at the expense of uncontrolled growth of biota of various ecological groups has been revealed. That contributes, to a certain extent, to the process of water purification from Cs-137 and Sr-90 with simultaneous increase of radioactivity of river-bed sediments.

### 1.5.2. Underground waters

Regarding the contamination by radionuclides (of Chernobyl origin) of underground water, it is necessary to point out that the "background" ("pre-Chernobyl") indices of specific water activity on Cs-137 and Sr-90 were as small as the thousands share of Bq/l. But already in 1987 its sharp increase was registered.

In the territories of the Nizhne-Pripyatskaya zone with the density of contamination exceeding  $1480 \text{ kBq/m}^2$  the specific activity of the ground waters reached  $3,0 \text{ Bq/l}$  on Cs-137 and  $0,7 \text{ Bq/l}$  on Sr-90. In the alienation zone the radionuclides concentrations reached  $3,0-5,0 \text{ Bq/l}$  on caesium and  $1,0-2,0 \text{ Bq/l}$  on strontium. In the Sozh zone the maximum indices also reached this level, but on average these concentrations were lower.

There is a direct correlation observed between the density of contamination and content of radionuclides in the waters of the first horizon from the surface. On territories contaminated up to a density of  $555$  to  $1480 \text{ kBq/m}^2$  on Cs-137 the radionuclides concentration in ground waters makes up  $0,2-2,0 \text{ Bq/l}$  on Cs-137 and  $0,03-0,1$  on Sr-90 both in the Nizhne-Pripyatskaya and Sozh zones. For ground waters the feed area of which is contaminated by Cs-137 to the

level of  $185-555 \text{ kBq/m}^2$ , concentration was  $0,01-1,0 \text{ Bq/l}$  on Cs-137 and  $0,01-0,07 \text{ Bq/l}$  on Sr-90.

The analysis of ground waters contamination by Cs-137 and Sr-90 shows that concentration of radionuclides in them has the tendency for increase with growth of contamination density of soils and depends on rate and composition of the aeration zone and other factors. In the Nizhne-Pripyatskaya zone the content of Cs-137 and Sr-90 in the underground waters before the catastrophe made up  $3,7 \cdot 10^{-4} - 3,7 \cdot 10^{-3} \text{ Bq/l}$  and  $3,7 \cdot 10^{-4} - 1,85 \cdot 10^{-3} \text{ Bq/l}$ , and in 1990-1994 -  $0,1 - 0,7 \text{ Bq/l}$  and  $0,01 - 0,07 \text{ Bq/l}$  correspondingly.

The main factors determining the contamination of surface waters in the future are: the drift of radionuclides from the water-collecting areas and processes of biological circulation in water systems and further river bed transfer. Owing to these reasons and radionuclides decay the density of radioactive contamination of water flows and water collectors as well, will be decreasing gradually. In the process of the drift of Cs-137 and Sr-90 out of riverside landscapes the tendency to increase the difference in their flow to open water basins at the expense of the larger mobility of strontium will be marked. Less contaminated riverside areas situated down-stream can be further contaminated by radionuclides due to the secondary transfer at its most active during rainy seasons, floods and high waters. Land-locked ponds and lakes will be influenced by a drift of radionuclides from the surrounding areas. The specific activity of surface waters may significantly vary being connected with the extreme situations (droughts, high water, rains).

### 1.6. Radioactive contamination of forest and other plant communities

In the result of the Chernobyl NPP accident  $1,73$  mln. ha of woods (Table 1.2.) or  $25\%$  of forests of the republic appeared in the radioactive contamination zone.

Table 1.2. Radioactive contamination of forests of Belarus

Radioactive contamination zones on Cs-137, $\text{kBq/m}^2$	Coniferous species thous. ha		Harddeciduous, thous. ha		Softdeciduous, thous. ha			
	Total	Incl. pine	Total	Incl. oak	Total	Incl. birch	Incl. aspen	Incl. alder
37-185	762,8	691,8	73,2	67,0	280,7	170,1	18,4	91,5
185-555	188,8	170,2	19,1	17,6	71,7	43,7	5,4	22,3
555-1480	90,1	80,6	9,0	8,3	34,0	20,8	2,8	10,2
> 1480	24,5	21,1	2,1	2,1	9,2	5,7	0,8	2,5
Total	1066,2	963,7	103,4	95,0	395,6	240,3	27,4	126,5

In the first days after the Chernobyl NPP accident about  $80\%$  of all radioactive fall-outs on forest areas was checked by the above ground parts of woods and about  $20\%$  settled down on the ground mantle.

At the end of summer 1986 in the above ground phytomass there were left  $13-15\%$  of the total amount of radionuclides. Beginning from 1988 on the background of the continuing self-cleaning of tops there is noted the increase of root inflow of Cs-137 and Sr-90 radionuclides to the above ground phytomass.

At present, in the above ground part there are 5-7 % of radionuclides depending on the age and thickness of woods, trees species and conditions of growth. The research testifies to the continuing radionuclides accumulation process in the wood of the main wood-forming species.

The forecasting results show that forests contamination will increase and the main mechanism of radionuclides transfer to the wood layer will be root penetration. In the nearest 10-15 years the above ground phytomass, 30-years pine forest in particular, will accumulate up to 10-15 % of the total amount of Cs-137 in large forests.

Depending on soil and landscape conditions and the level of moisturizing herbaceous accumulate radionuclides in a different manner, however, on meadows and marshes sedges, sorrels, beans, Gramineae have the greatest ability to accumulate them.

In the food products of the forests such as mushrooms and berries (whortleberries, cranberries, wild strawberries) Cs-137 content exceeds the permissible norms (dried mushrooms - 3700 Bq/kg, berries - 185 Bq/kg) even on the territories with slight density of soil contamination - 37-100 kBq/m<sup>2</sup>. The radioactive contamination of forest food that limits its usage should be expected in the next 30-40 years on the territories with contamination density of 150 kBq/m<sup>2</sup> and higher.

The testing of the seeds quality and genetic changes in the wood species progeny has shown that in considerably severe conditions of radioactive contamination survival rate of pine seedlings from radioactively contaminated territories is decreasing, their immunity to fungal diseases is falling. Atypical effects take place: atypical branching of pollen tubules and formation of swells.

The genetic analysis of the wood species seeds has shown that even on the territories with relatively low Cs-137 contamination density (about 1000-1500 kBq/m<sup>2</sup>) there is observed the 2 times increase of mutation rate.

On the soils with Cs-137 contamination density over 3700 kBq/m<sup>2</sup> anomalies in growth and development of herbaceous and bush plants - the so called radiomorphoses are registered. Morphological anomalies of plants are the consequence of violation of organoformation processes connected with the arising anomalies of cells division. The following anomalies are observed: twisting and tumour swelling of stems, leaves asymmetry and curl, growth of side shoots, dwarf state, bushiness, gigantism.

Deviations on the cellular level are also observed. In dividing cells of the plants there happen chromosome breaks. The most radiosensible species are plantain, yarrow and others.

The monitoring of plants natural populations testifies that plant complexes as a whole are relatively resistant to radiational exposure.

The majority of plants species on the alienation territories have not undergone material changes. In spite of the absence of visible violations on population and ecosystematic levels in plants communities it is impossible to rule out the possibility of changes in phytocenosis with predominance of the most radioresistant species.

### 1.7. Fauna state

The radionuclides accumulation by animals is equal to the radioactive contamination of the territory.

The highest levels of radionuclides content in various fauna representatives were observed in the first year after the accident (Fig. 1.13.).

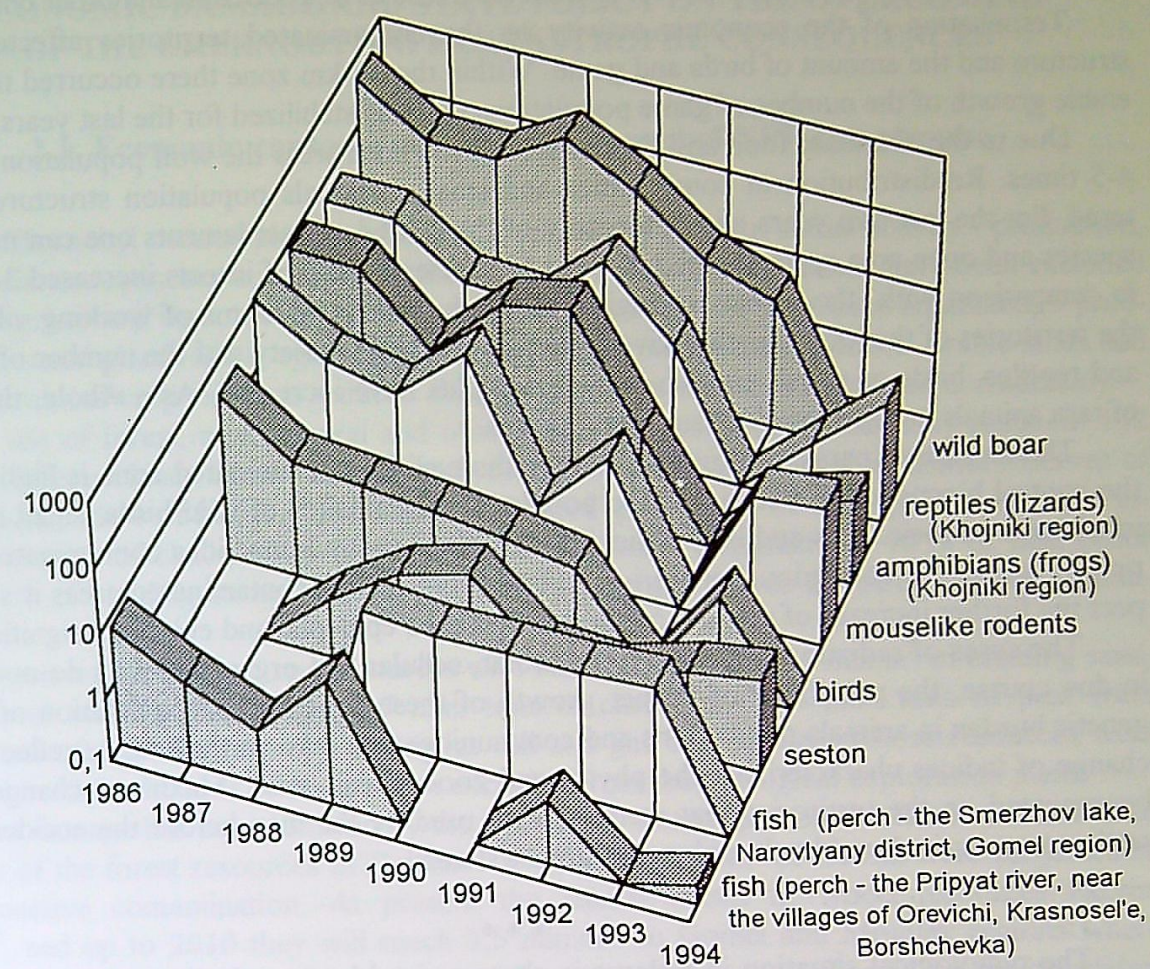

Fig. 1.13. Dynamics of radionuclides content (kBq/kg of body raw mass) in different systematic and ecological groups

In 1987 their noticeable decrease happened (5-10 times). In the following period (1988-1990) the above mentioned process slowed down considerably and in some cases the radionuclides content in some groups of animals (fish, amphibians, small mammals) inhabiting the most contaminated territories reached the level of 1986.

At present the tendency to radionuclides content stabilization in the animals organisms is observed. The inhabiting of animals in the radionuclides contaminated biogeocoenoses have not led to visible radiational effects on the population level yet. At the same time a number of changes have been revealed in some groups of animals. Hematological research showed that ground invertebrates have changes in their blood formula that manifest themselves in increase of the dead cells, cytological and morphological violations. Morphometric analysis showed 1,5-2 times decrease in body size in the representatives of mesofauna from alienant territory. Absolute and relative fertility of fish decreased. Violations in the processes of growth and development of reproductive cells and their structures are registered. The genetic changes in some species of amphibia and reptiles that manifest themselves in increase of aberrational cells rate, are revealed. European red field mouse had the slowing down of young stock maturing

and reduction of multiplication (fission) rate. The analysis of other animals demographic indices also shows the violation in sex correlation, decrease in reproduction and other changes.

Termination of the economic activity on the contaminated territories affected species structure and the amount of birds and game. Within the 30-km zone there occurred the considerable growth of the number of game populations that has stabilized for the last years.

Due to the abundant food and the absence of the hunt pressure the wolf population increased 4-5 times. Re-distribution in communities and small mammals population structure is registered. For the last two years on the territory of the settled out settlements one can meet forest species and open area species. The number and species variety of insects increased 3-3,5 times in comparison with those that are registered on the individual farms of working villages. On the territories of the locked meliorative systems the species variety and the number of amphibians and reptiles, birds of marsh and wood-bush complex have increased. As a whole, the number of rare animals has increased in faunal complexes.

The tension of parasitic situation in the radionuclides contaminated zone is higher than in the control biocoenoses. Fauna and the population of parasites of wild birds, small mammals, inhabitants of their nests and blood-sucking insects in the radionuclides contaminated areas is richer than on the contiguous territories. In due course in the contaminated areas it should expect the further increase of number of species that have epidemic and epizootic significance.

The cases of radiational effects on molecular, cellular and organism levels do not exclude, in due course, the possibility of further growth of these processes, accumulation of negative genetic burden in animals populations and communities that may, in the end, be reflected in the change of indices characterizing the phyto- and zoocoenosis state. Maximum changes should be expected on the territories that were actively used by the man before the accident: in the settlements, agricultural lands and meliorative systems.

\* \* \*

The radiological situation in Belarus is characterized by complexity and heterogeneity of contamination of the territory by alpha-, beta- and gamma-radioactive substances with various periods of half-life, presence of radioactive isotopes practically in all components of ecosystems and their involvement in the geochemical and trophic cycles of migration. All this calls forth plurality of ways of the external and internal irradiation of the population and jeopardizes its health. The dynamics of radiation situation in the nearest future and for the perspective will be determined by nuclear decay, radionuclides migration, the transformation of forms of their existence.

There is registered the number of radiation-induced changes of flora and fauna, especially on molecular - cellular and organism levels and less marked - on the population and ecosystematic levels. The series of consequences for natural complexes and animals is connected with changes in economic activity and nature use. The accumulation of genetic burden and other changes in the systems of organism and metabolic processes may result in the change of plants and animals communities. This demands further study of radiation situation dynamics, the radionuclides behaviour in soil, water, air, inclusion of the radionuclides into the food chains, accumulation in plants and organisms of animals and estimation of biological effects.

## CHAPTER 2 ECONOMIC DAMAGE AND STATE POLICY ON THE OVERCOMING OF THE CHERNOBYL NPP CATASTROPHE CONSEQUENCES

### 2.1. Economic consequences of the Chernobyl NPP catastrophe

The Chernobyl catastrophe has affected all spheres of the man's vital activity - production, culture, science, economy and etc. 2,64 thousand km<sup>2</sup> of agricultural lands have been excluded from the agricultural turnover. 54 collective farms and sovkhozes have been liquidated, 9 processing industrial plants of the agroindustrial complex have been closed down. Arable lands and gross agricultural crop yield has reduced sharply, the cattle stock has decreased considerably.

The use of forest, raw, mineral and other resources has been considerably reduced. 132 layers of different kinds of raw and mineral resources including 47 % of industrial reserves of foundry sand, 19 % of building and silicate, 91 % of glass sands of the republic, 20 % of industrial reserves of chalk, 13 % of clay reserves for brick manufacture, 40 % of heat-proof clays, 65 % of building stone reserves and 16 % of cement source appeared in the contaminated zone.

22 layers of mineral and raw resources with balance reserves of 5 mln.m<sup>3</sup> of building sand, sandy-gravel materials and clays, 7,7 mln. tons of chalk and 13,5 mln. tons of peat were brought out of use. The territory of Pripyat oil and gas bearing field whose resources were evaluated in 52,2 mln. tons of oil has been excluded from the geological exploration plans.

Great damage has been incurred by the Chernobyl catastrophe on the forestry. More than a quarter of the forest resources of Belarus - 17,3 thousand km<sup>2</sup> of forests were subjected to the radioactive contamination. At present the annual losses of wood resources exceed 2 mln.m<sup>3</sup>, and up to 2010 they will reach 3,5 mln.m<sup>3</sup>. In Gomel and Mogilev regions where correspondingly 51,6 and 36,4 % of the total forest area are contaminated by radionuclides, wood felling is completely terminated on the territories with Cs-137 contamination density of 555 kBq/m<sup>2</sup> and higher.

340 industrial enterprises are situated in the contamination zone and the conditions of their functioning have considerably changed. The population resettlement from the most affected areas has resulted in closing down a number of industrial enterprises and establishments of the social sphere. Others incur heavy losses and continue to do so owing to the decline in production volumes, partial recoupment of means invested in buildings, structures, equipment, land - reclamation systems. Losses of fuel, raw materials and materials are considerable.

The damage incurred in the republic by the Chernobyl catastrophe, taking into account the 30-years period needed for its overcoming, is estimated to be 235 billion US\$ that is equal to 32 annual budgets of the republic of 1985. Here belong the losses connected with the deterioration of population health, damage incurred in industry and social sphere, agriculture, building complex, transport and communication, housing, with contamination of raw, mineral, land, water, forest and other resources, and also additional cost connected with the realization of measures on liquidation and minimization of the catastrophe consequences and providing safe living conditions for the population. The structure of the economic damage of the Republic of Belarus from the Chernobyl NPP catastrophe on the national economy installations and types of losses are represented in Fig. 2.1.